

# Cantech Oilfield Equipment Ltd

5160 Skyline Way, NE, Calgary, Alberta, T2E 6V1  
Tel & Fax: (403)-230-1336, Cell Phone: (403)-669-9390

## Certificate of Conformance

---

Equipment Type: Pipe Cone for supporting 2" – 8" pipes or 2 3/8" – 8 5/8" tubular

Drawing Number/Model: 10150-01

Unit Number and S/N: N/A

Rated Capacity: 1,650lbs for supporting 2" Pipe or tubular OD 2 3/8"  
2,250lbs for supporting 8" pipe or tubular OD 8 5/8"

Date of Certification: April, 2013

Manufacturer: Predator Plastics Inc

This is to certify that the pipe cone (drawing is attached) has been tested by Predator Plastics in their Drayton Valley's facility. Cantech has reviewed the testing procedures and results. It is our opinion that the above product is safe to use under the rated capacity stated above.



---

George Hu, P.Eng., M62274  
Cantech Oilfield Equipment Ltd.  
Permit to Practice: P10445

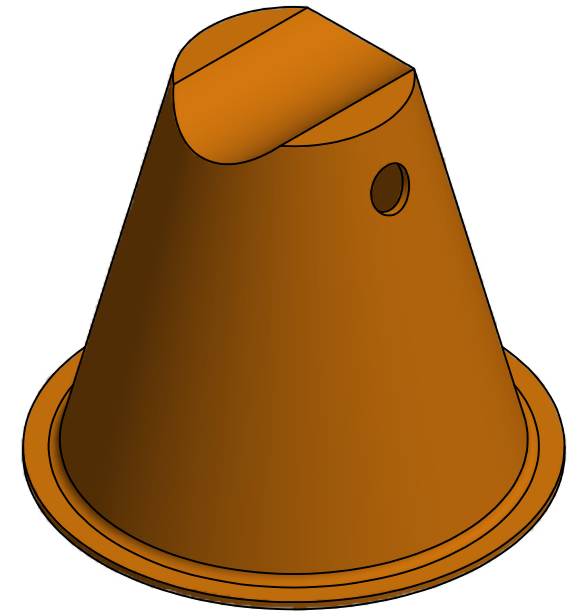
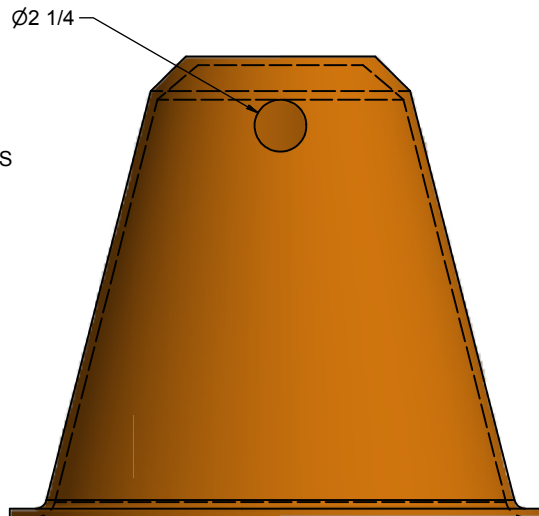
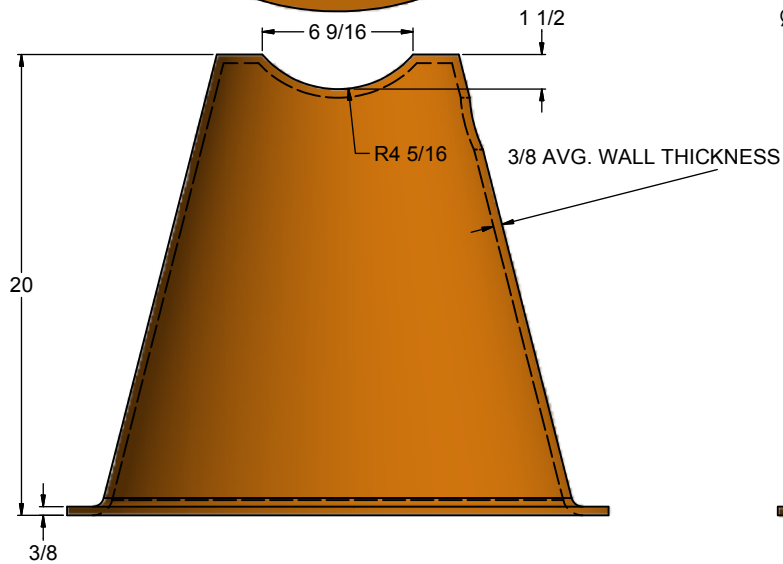
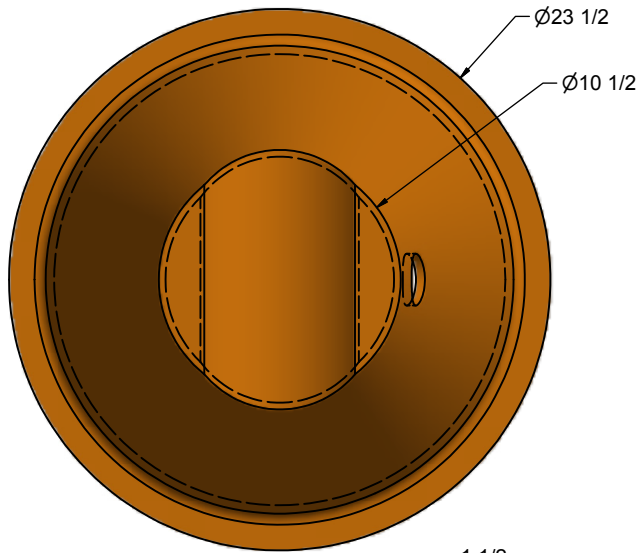

ISO VIEW

**NOTES:**

- PIPE CONE USED TO SUPPORT 2" TO 8" PIPE.
- EACH CONE WEIGHS 13.5 LBS
- MATERIAL: NOVA SURPASS RMS341UG (MELT INDEX:3.5, DENSITY: .941G/CM3) sHDPE POWDER

<b>PREDATOR PLASTICS INC.</b>		DESCRIPTION	DATE	BY
		<b>PIPE CONE 2" - 8"</b>		
<small>TOLERANCES UNLESS OTHERWISE SPECIFIED</small> X.X ± 0.1 X.XX ± 0.01 X.XXX ± 0.003 ANGLES ± 1° FRACTIONS ± 1/32"	DRAWN BY: <b>A. DELORME</b>	SCALE: <b>NTS</b>		
<small>PRINTED IN CANADA FOR PREDATOR PLASTICS INC. THIS DOCUMENT AND THE INFORMATION CONTAINED MAY NOT BE REPRODUCED OR USED IN ANY WAY OTHER THAN WITH THE WRITTEN AUTHORIZATION FROM PREDATOR PLASTICS INC.</small>	DATE: <b>13/03/2013</b>	JOB NUMBER:		
	COMPANY:	FILE: <b>10150-01</b>		